

- Clutch with hydraulic release device 1

REMOVING-REFITTING

- Lining - Driven disc 2
- Refitting 3

CLUTCH OPERATION

- Thrust bearing 3
- Selector fork 4
- Sleeve - Clutch pump 5
- Operating cylinder 8

CLUTCH WITH HYDRAULIC RELEASE MECHANISM

In order to reduce the force exerted on the clutch pedal and to facilitate the release mechanism, a hydraulic device has been fitted. This device comprises a reservoir (1), a pump (2) fixed to the pedals and an operating cylinder (3) fixed to the bell housing by a bracket (4).

The use of a hydraulic device allows improved and more reliable operation compared with a mechanical device; in addition as the release mechanism has been made more gradual there are no longer any jerking, particularly when high torques are being transmitted.

A more comfortable ride is obtained because the vibrations sent by the power unit due to the damping effect of the oil are reduced.

The adoption of this device allows a constant adjustment of the clutch pedal height.

On the DELTA HF 16 V the clutch assembly has a traction release mechanism; this name stems from the fact that when the pedal is pressed the clutch is pulled by the coupled thrust bearing rather than thrust in the conventional way.

This type of clutch has been used because due to the high torque to be transmitted the size of the clutch assembly has to be increased in order not to alter the force on the pedal during the release action.

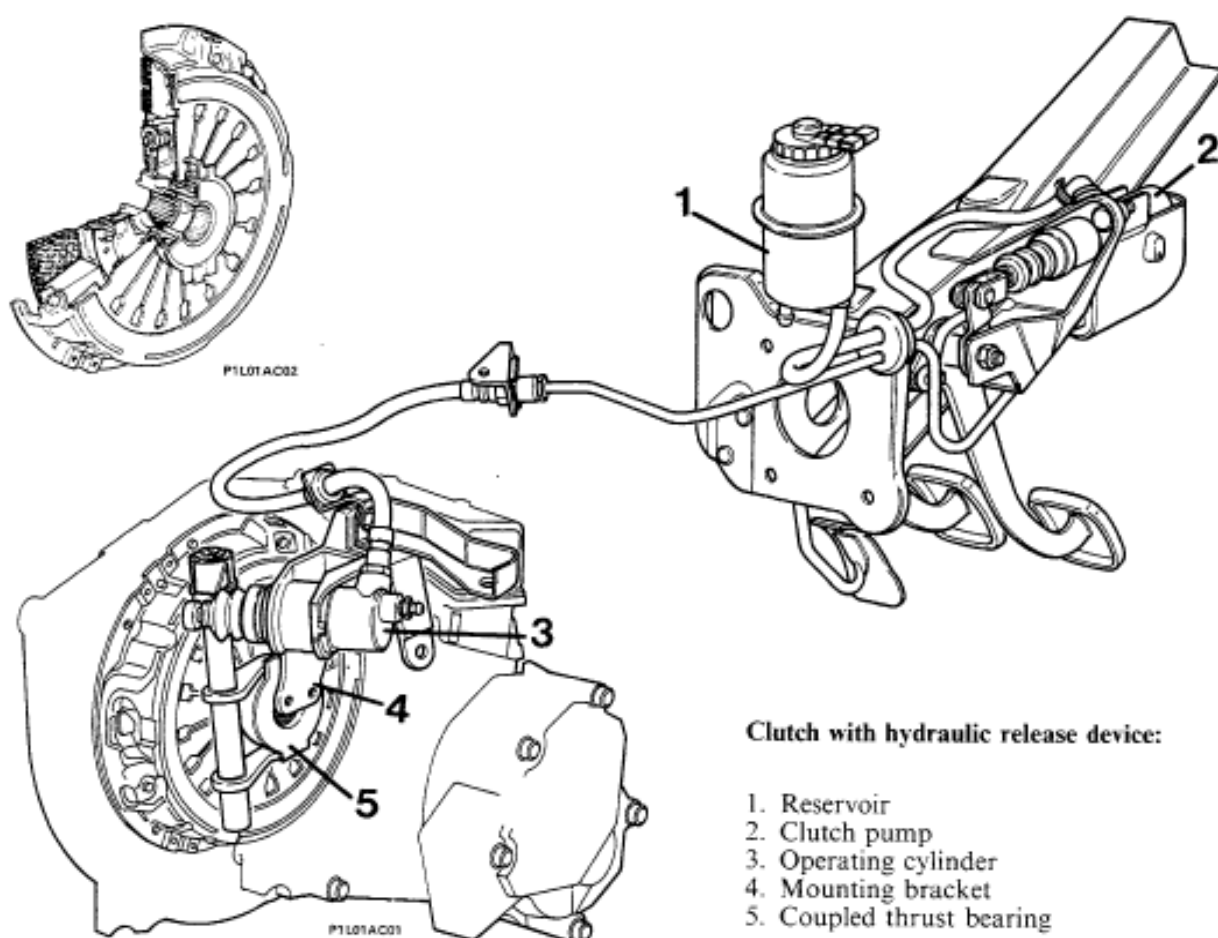

Clutch with hydraulic release device:

1. Reservoir
2. Clutch pump
3. Operating cylinder
4. Mounting bracket
5. Coupled thrust bearing

Clutch

Removing-refitting

DELTA HF integrale 16v

18.

NOTE In order to remove the clutch the gearbox-differential unit has to be removed

With the gearbox-differential unit removed, proceed as follows:

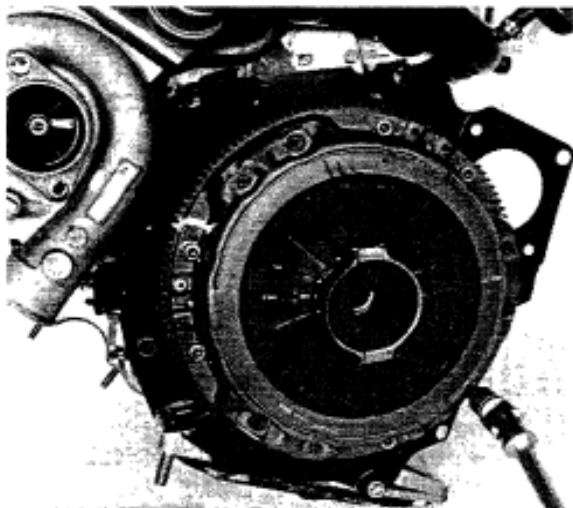

P1102AC01



P1102AC02

Removing clutch assembly

LINING - CLUTCH PLATE

If the driven disc lining is excessively worn then the complete clutch plate has to be replaced



P1102AC03

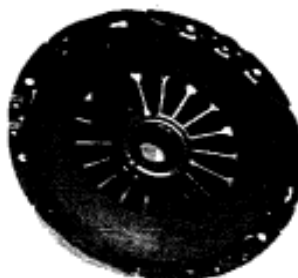

P1102AC04

If there are signs of wear, overheating or deep grooves in the linings, replace the assembly

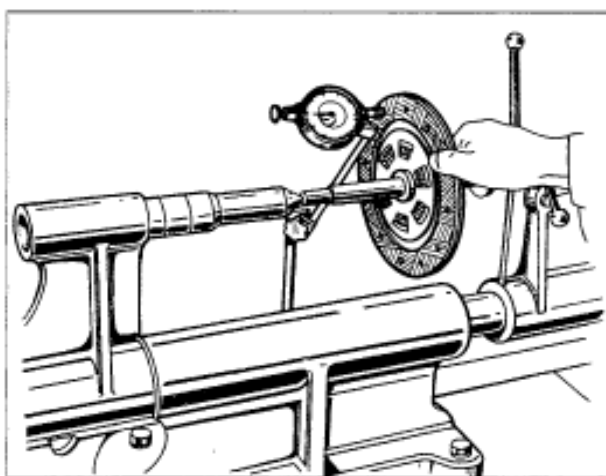

P1X003C06

Driven disc alignment check

The run out on the disc must not be more than 0.25 mm.



Removing clutch thrust bearing

REFITTING

Alignment of driven disc for refitting clutch assembly using centering tool

THRUST BEARING

Positioning thrust bearing on gearbox main shaft

The bearing should not show signs of sticking or noisiness during rotation or else it must be replaced

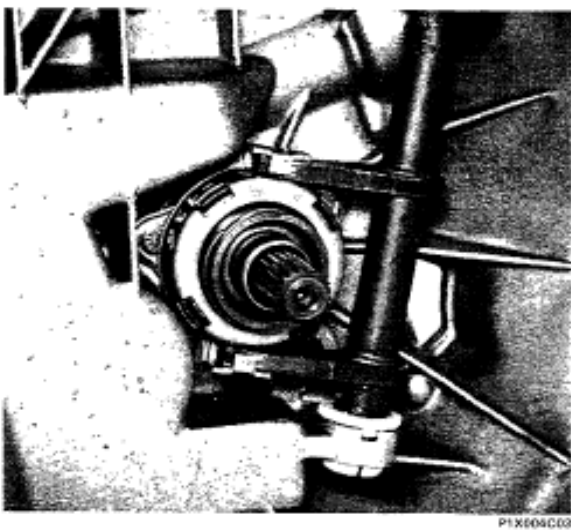
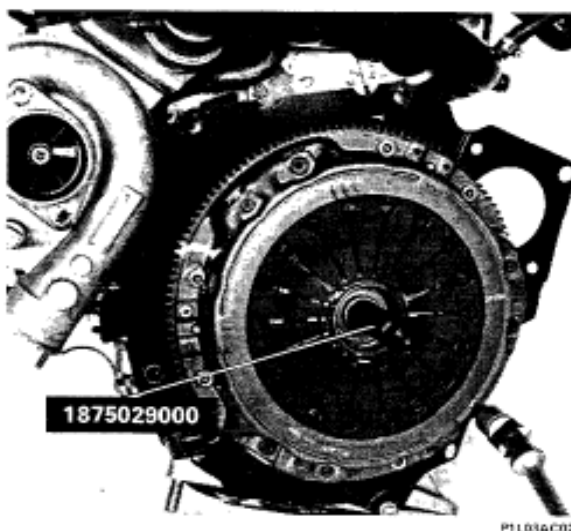

18.

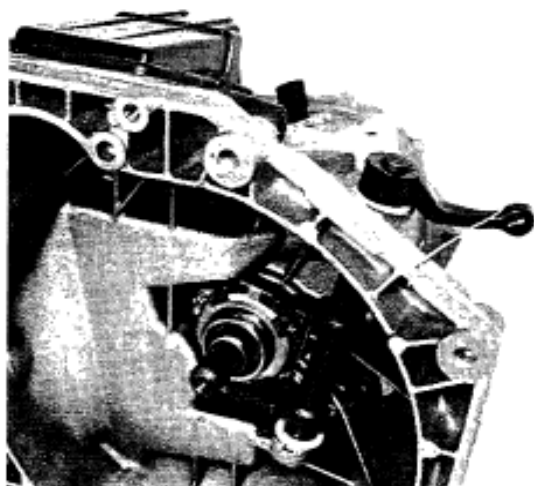

P1X005C01

NOTE *In order to refit the gearbox to the engine the clutch release fork must be suitably fixed positioning it as shown in the diagram*

Fixing clutch release fork

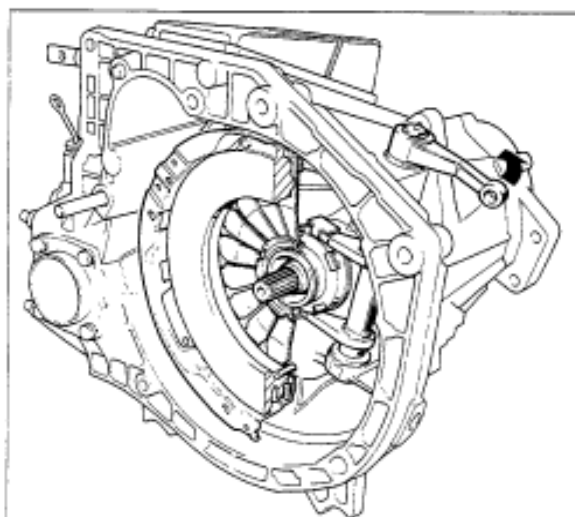

P1X006C02

NOTE *After refitting the gearbox, move the selector fork in the direction shown by the arrow to allow the thrust bearing to be positioned in its seat*

Positioning thrust bearing in its seat

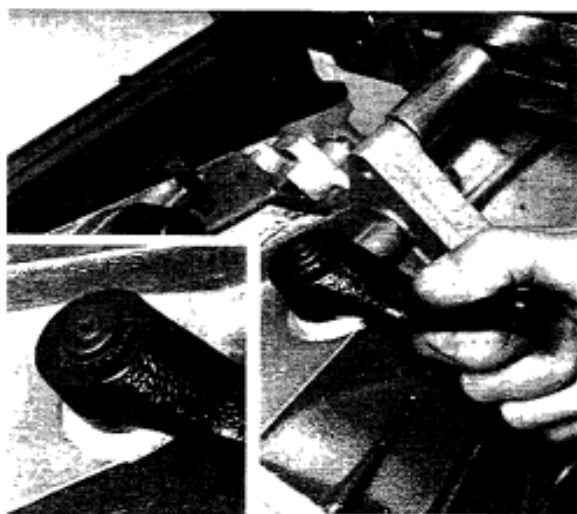

P1X005C04

P1X006C03

SELECTOR FORK

Removing-refitting selector fork

P1X006C02

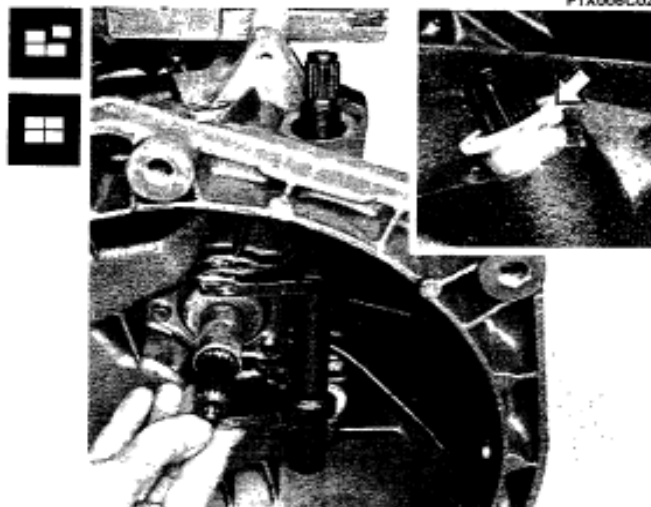

Removing-refitting fork control shaft

The bushes should be replaced each time the clearance for the fork control shaft is too large.

P1X006C01

P1X006C04

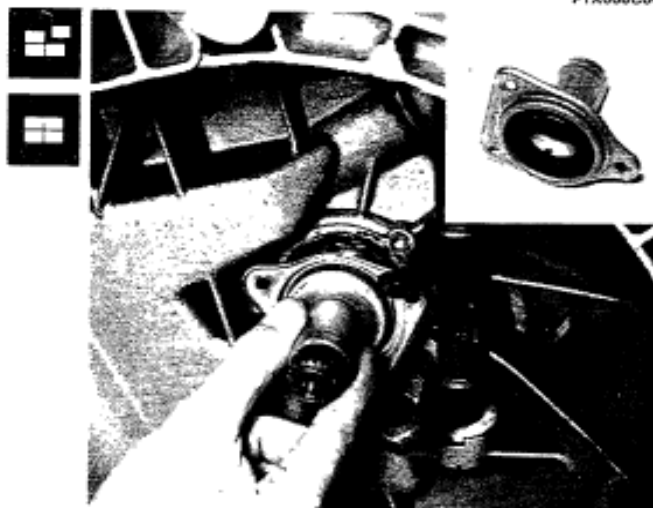

SLEEVE

Removing-refitting thrust bearing sleeve

The seal should be replaced each time oil spillages from the gearbox are noticed.

P1X006C03

CLUTCH PUMP

NOTE *The clutch pump is fixed to the pedals. In order to illustrate the operations required to remove and refit it the pedals have been removed.*



P1X007C03

P1X007C04

Removing-refitting pin fixing clutch pump to pedal

18.



Removing-refitting clutch pedal return spring

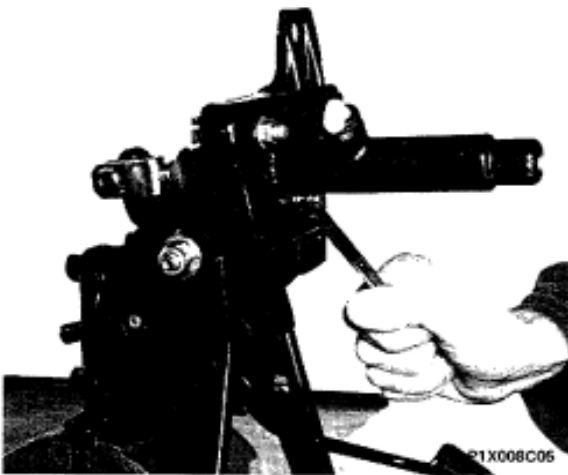

Removing-refitting clutch pump



P1X008C06

View of clutch pump



P1X009C1

Removing-refitting protective boot



P1X009C2

Removing-refitting clutch pump piston circlip



P1X009C3

Removing-refitting clutch pump piston and operating lever

18.

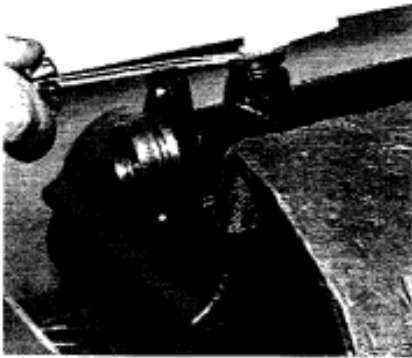

PIX010C01

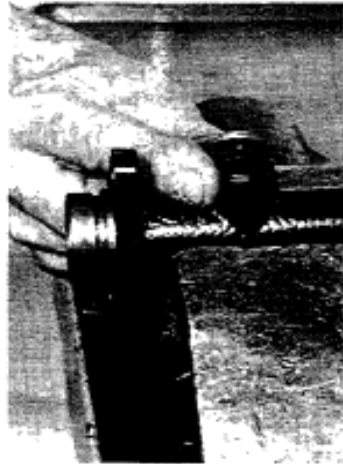

PIX010C02



Removing-refitting supply union and seal



PIX010C03

Clutch pump components

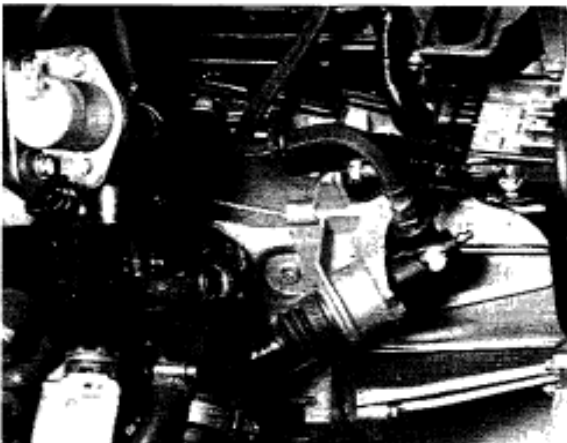

OPERATING CYLINDER

Removing-refitting clutch operating cylinder

Remove the circlip fixing the operating cylinder to the mounting bracket and extract the operating cylinder after having disconnected the flexible oil pipe

P1L0BAC01

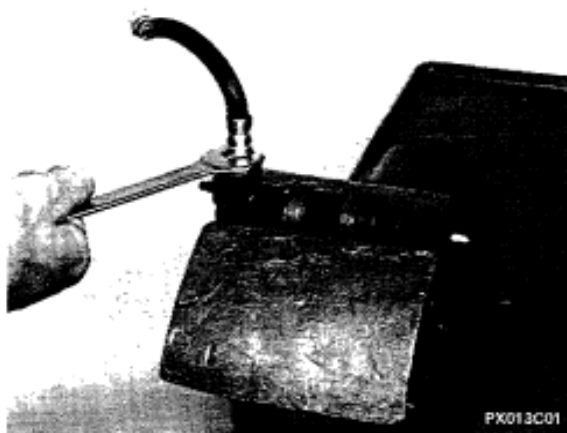

Removing-refitting flexible pipe



Removing-refitting protective boot and push rod



Removing piston

18.



Removing-refitting bleed screw



Clutch operating cylinder components

When the hydraulic system components have been refitted carry out the:



Bleeding of the air from the clutch